

Motor Driver(5-Phase microstepping driver)

KR-A55ME-2Z/3Z

M A N U A L



Thank you very much for selecting Technodrive products.
For your safety, please read the following before using.

Caution for your safety

- ※Please keep these instructions and review them before using this unit.
- ※Please observe the cautions that follow;
- Warning** Serious injury may result if instructions are not followed.
- Caution** Product may be damaged, or injury may result if instructions are not followed.
- ※The following is an explanation of the symbols used in the operation manual.
- Caution:**Injury or danger may occur under special conditions.

Warning

- In case of using this unit with machinery(Nuclear power control, medical equipment, vehicle, train, airplane, combustion apparatus, entertainment or safety device etc), it is required to install fail-safe device, or contact us for information on type required.** It may cause serious human injury or a fire, property.
- Installation, connection, operation, control, maintenance should be carried out by person who has been qualified.** It may cause a fire, human injury or give an electric shock.
- Please use DC power with reinforced insulating the primary and secondary part for the DC power product.** It may give an electric shock.
- Please install this unit after consider countplan against power failure.** It may cause human injury or damage to product by releasing holding torque of motor.
- Do not use this unit outdoors or place where there are explosiveness, flammable, corrosive gas, water and frequent vibration etc.** It may cause a fire or give an electric shock.
- Do not disassemble or modify this unit. Please contact us if it required.** It may cause a fire, give an electric shock or damage to product.
- Please install protection equipment on board type product.** It may cause a fire.

Caution

- Power input voltage must be used within rating specification and power line should be over than AWG NO. 18(0.75mm²).** It may cause a fire or give an electric shock.
- Please check the connection before power.** It may cause a fire or give an electric shock.
- Please turn off when power failure occurred.** It may cause human injury or damage to product due to sudden movement by recovering from power failure.
- Do not touch during the operation or after a while of operation.** It may cause a burn due to high temperature in surface.
- The emergency stop should be enabled during the operation.** It may cause human injury or damage to product.
- Please apply power after checking control input signal.** It may cause human injury or damage to product by sudden movement.
- Do not turn on the HOLD OFF signal input while it is maintaining vertical position.** It may cause human injury or damage to product by releasing holding torque of motor.
- Please install a safety device when need to remain the vertical position after turn off the power.** It may cause human injury or damage to product by releasing holding torque of motor.
- Please check if HOLD OFF signal input is ON when need to set the output manually.** It may cause human injury by sudden movement.
- Please stop this unit when mechanical problem is occurred.** It may cause a fire or human injury.
- Do not touch the terminal when during the insulation dielectric strength test or insulation resistance measurement.** It may give an electric shock.
- Please observe rating specification.** It may cause a fire, give an electric shock or damage to product.
- In cleaning the unit, do not use water or an oil-based detergent.** It may cause a fire or give an electric shock.
- Please separate as industrial waste when disuse this unit.**

※ The above specifications are changeable at anytime without notice.

Features

- Simultaneous operation of 2, 3-axis by single 24VDC.
- Settable 16 step angles and enable to rotate with 250 microsteps and 125000 pulse.
- Includes auto current down, self-diagnosis function.
- Small, light weight and advanced quality by custom IC and surface mounted circuit.
- Photocoupler input insulation method to minimize the effects from external noise.

Specifications

Model	KR-A55ME-2Z	KR-A55ME-3Z
Power supply	20-35VDC 5A[Max.](-10% , $+20\%$)	20-35VDC 7A[Max.](-10% , $+20\%$)
RUN current	0.4~1.4A/Phase	
Drive method	Bipolar constant current pentagon drive	
Resolution(Rotating angle)	1, 2, 4, 5, 8, 10, 16, 20, 25, 40, 50, 80, 100, 125, 200, 250 division	
CW/CCW Input pulse	Pulse width	Min. 0.25 μ s
	Pulse interval	Min. 0.25 μ s
	Rising/Falling time	Max. 1 μ s
	Frequency	Max. 500kpps
	Voltage	High: 4~8VDC, Low: 0~0.5VDC
Current	10~20mA	
Ambient temperature	0~40°C(at non-freezing status)	
Ambient humidity	35~85%RH(at non-dew status)	
Unit weight	Approx. 292g	Approx. 411g

※ There is torque difference by input power.

Dimensions

KR-A55ME-2Z (Unit:mm)

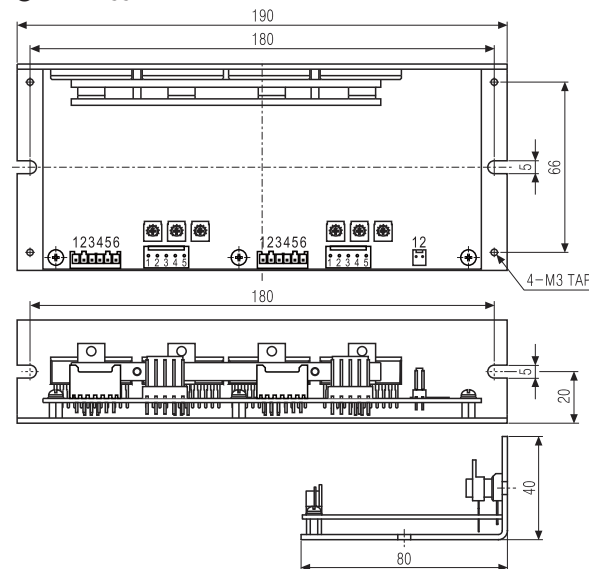

KR-A55ME-3Z

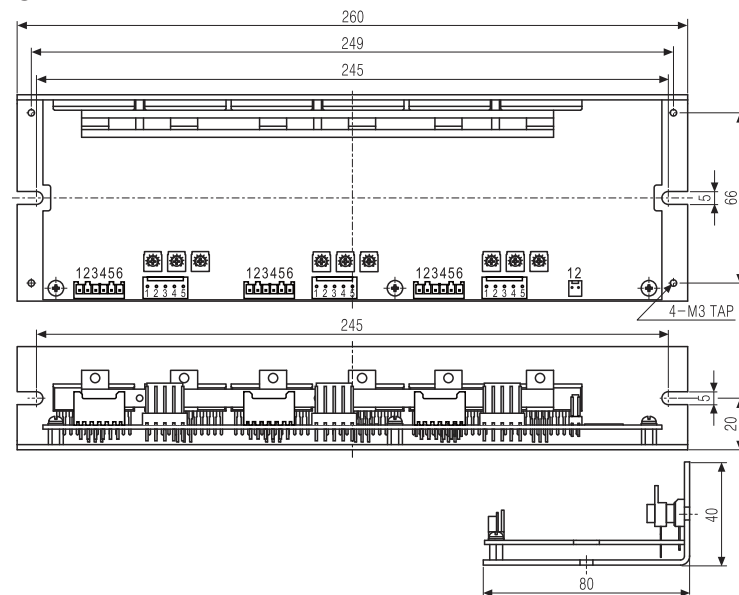

※ Accessory connector specification (manufacturer: JST)

	Model	Quantity (2Z)	Quantity (3Z)
2-pin power connector	VHR-2N	1	1
5-pin motor connector	VHR-5N	2	3
6-pin signal connector	XAP-06V-1	2	3
Power/Motor connector pin	SVH-21T-P1.1	12	17
Signal connector pin	SXA-001T-P0.6	12	18

Time charts

CW / CCW Input(CW : Clockwise direction from the front view of shaft)

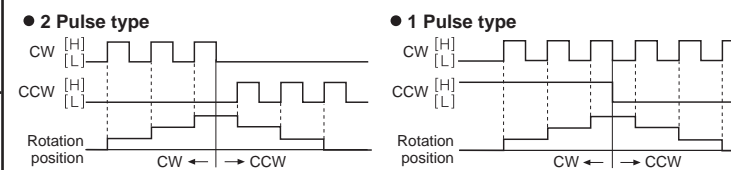

Connections

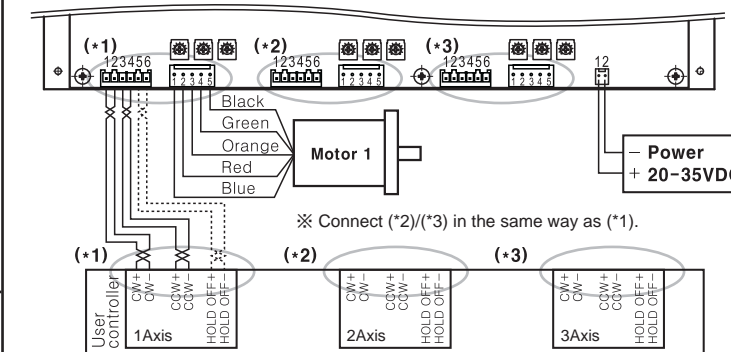

Input-Output diagram

<KR-A55ME-2Z/3Z Driver inner circuit>

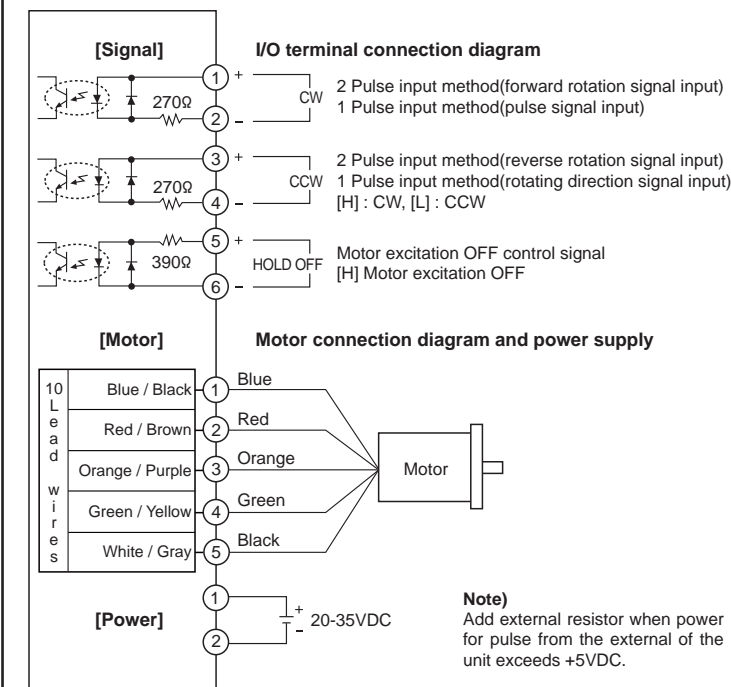

Function

Selectable function switch

No	Name	Function	Switch position	
			ON	OFF
1	TEST	Self diagnosis function	250pps rotation	Normal
2	1/2 CLK	Pulse input method	1 Pulse input	2 Pulse input
3	CURRENT DOWN	Auto Current Down	No use	Use

- TEST**
 - ※ It rotates at a speed of 250pps in Full Step and it is changed depending on resolution.
 - ※ It rotates to CCW in 1 Pulse input method and CW in 2 Pulse input method.
- 1/2 CLK**
 - ※ Pulse input method selection
 - ※ 1 Pulse method : Input pulse signal input in CW and rotating direction signal in CCW. It rotates to CCW when [L] and CW for [H].
 - ※ 2 Pulse method : Motor is rotated to CW when input pulse in CW and to CCW when input pulse in CCW.
- CURRENT DOWN**
 - ※ It is to reduce RUN current according to the setting rate of STOP current switch when motor stops in order to reduce motor's heat generation.
 - ※ Current is reduced from approx.500[ms] after the last pulse input.

Setting RUN current

Switch No	0	1	2	3	4	5	6	7	8	9	A	B	C	D	E	F
Current (A/Phase)	0.4	0.5	0.57	0.63	0.71	0.77	0.84	0.9	0.96	1.02	1.09	1.15	1.22	1.27	1.33	1.4

- RUN current is phase current for 5 phase stepping motor.
- There can be an error in RUN current setting value by driving frequency.
- RUN current should be used within the rated current of motor, or it may cause overheating, step-out and loss of torque.

Setting STOP current

Switch No	0	1	2	3	4	5	6	7	8	9	A	B	C	D	E	F
%	27	31	36	40	45	50	54	58	62	66	70	74	78	82	86	90

- STOP current is phase current provided to 5-phase of stepping motor to be stopped.
- The switch setting value of STOP current is a percentage of RUN current switch setting current value.
- There can be an error in STOP current by coil impedance of motor.
- This function shall be operated when CURRENT DOWN switch is set to OFF. In case CURRENT DOWN switch is set to ON, RUN CURRENT shall be provided both when a motor stops and when a motor runs.

HOLD OFF function

- HOLD OFF is [H], the excitation is released, because current provided to each phase is cut off.
- HOLD OFF is [L], the excitation is in a normal status.
- It rotates motor axis by external force or is used for manual positioning.
- Input H/L means ON/OFF of photocoupler in a circuit.

Setting micro step(Microstep:Resolution)

Switch No	0	1	2	3	4	5	6	7	8	9	A	B	C	D	E	F
Resolution	1	2	4	5	8	10	16	20	25	40	50	80	100	125	200	250

Setting resolution(MS1)

- It drives a motor dividing basic step angle(0.72°) by setting value of resolution.
- The calculation formula of divided step angle is as below.
1 step angle of 5-phase stepping motor = $\frac{\text{Basic step angle}(0.72^\circ)}{\text{Resolution}}$
- When resolution is changed during the operation of motor, it may cause a step-out of motor.

Caution for using

- Caution for signal input**
 - Do not input CW, CCW signal at the same time in 2 Pulse input method. It may not work properly if another signal is supplied when one of them is ON.
 - In case, the signal input supply is higher than rated supply expressed on the specification, please connect the additional resistor to external part.
- Caution for supplying power**
 - Use the power enough to supply the run current when turn on the power.
 - The current value indicated on power supply is the max. input of driver.
 - Please check the polarity of power before using.**
- Caution for wiring**
 - Use Twist pair(Over 0.2mm²) for the signal wire should be shorter than 2m.
 - Please use an electric wire is thicker than the motor lead when product the motor wire connection.
- Caution for installation**
 - In order to increase heat protection efficiency, keep the heat sink as close as possible to metal panel and keep it well-ventilated.
 - Excessive heat generation may occur on Driver. Keep the heat sink under 80°C when installing the unit.(In case it is over 80°C, forcible cooling shall be required.)
- Caution for using function switches**
 - Check the position of self-diagnosis switch before turn on the power. It may be dangerous if turn on the power in [ON] status, due to motor is worked instantly or cause a malfunction.
 - When the selection switch of input signal method is changed to 2 Pulse input method during the operation with 1 Pulse input method, it may be danger as the revolution way of the motor is changed conversely. Please do not change the input signal method during the operation.
- Installation environment**
 - It shall be used indoor
 - Altitude Max. 2000m
 - Pollution Degree 2
 - Installation Category II

※ It may cause malfunction if above instructions are not followed.